

The A Proctor Group Ltd

The Haugh
Blairgowrie
Perthshire PH10 7ER



Tel: 01250 872261 Fax: 01250 872727

e-mail: contact@proctorgroup.com

website: www.proctorgroup.com

Agrément Certificate

19/5653

Product Sheet 1

THE A PROCTOR GROUP VAPOUR PERMEABLE MEMBRANES

FIRESHIELD - FIRE RETARDANT BREATHER MEMBRANE FOR USE IN WALL APPLICATIONS

This Agrément Certificate Product Sheet⁽¹⁾ relates to Fireshield, for use as a fire retardant, vapour permeable membrane for timber, masonry and steel frame wall applications in domestic and non-domestic buildings, behind lightweight cladding panels and masonry facades
(1) Hereinafter referred to as 'Certificate'.

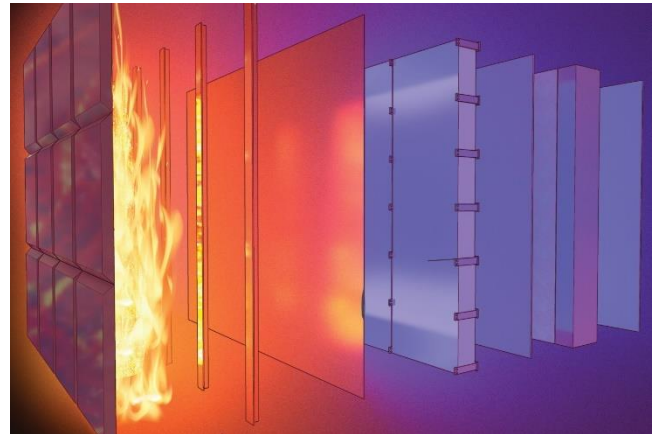

CERTIFICATION INCLUDES:

- factors relating to compliance with Building Regulations where applicable
- factors relating to additional non-regulatory information where applicable
- independently verified technical specification
- assessment criteria and technical investigations
- design considerations
- installation guidance
- regular surveillance of production
- formal three-yearly review.

KEY FACTORS ASSESSED

Weathertightness — the product will contribute to protecting a wall against water penetration (see section 6).

Risk of condensation — the product has low resistance to water vapour transmission and will reduce the risk of interstitial condensation (see section 7).

Strength — the product has adequate strength to resist damage during the construction of walls (see section 8).

Behaviour in relation to fire — the product has an enhanced performance in relation to reaction to fire classification (see section 9).

Durability — the product will have a life equal to that of the building in which it is installed (see section 11).



The BBA has awarded this Certificate to the company named above for the product described herein. This product has been assessed by the BBA as being fit for its intended use provided it is installed, used and maintained as set out in this Certificate.

On behalf of the British Board of Agrément

Date of First issue: 13 May 2019

John Albon
Chief Scientific Officer

Claire Curtis-Thomas
Chief Executive

The BBA is a UKAS accredited certification body – Number 113.

The schedule of the current scope of accreditation for product certification is available in pdf format via the UKAS link on the BBA website at www.bbacerts.co.uk
Readers are advised to check the validity and latest issue number of this Agrément Certificate by either referring to the BBA website or contacting the BBA direct.
Any photographs are for illustrative purposes only, do not constitute advice and should not be relied upon.

British Board of Agrément

Bucknalls Lane
Watford
Herts WD25 9BA

tel: 01923 665300
clientservices@bbacerts.co.uk
www.bbacerts.co.uk

©2019

Regulations

In the opinion of the BBA, Fireshield, if installed, used and maintained in accordance with this Certificate, can satisfy or contribute to satisfying the relevant requirements of the following Building Regulations (the presence of a UK map indicates that the subject is related to the Building Regulations in the region or regions of the UK depicted):



The Building Regulations 2010 (England and Wales) (as amended)

Requirement:	C2(b)	Resistance to moisture
Comment:		The product will contribute to a wall satisfying this Requirement. See section 6.1 of this Certificate.
Requirement:	C2(c)	Resistance to moisture
Comment:		The product can contribute to limiting the risk of condensation. See section 7.1 of this Certificate.
Regulation:	7	Materials and workmanship (applicable to Wales only)
Regulation:	7(1)	Materials and workmanship (applicable to England only)
Comment:		The product is acceptable. See section 11 and the <i>Installation</i> part of this Certificate.



The Building (Scotland) Regulations 2004 (as amended)

Regulation:	8(1)	Durability, workmanship and fitness of materials
Comment:		The use of the product satisfies this Regulation. See section 11 and the <i>Installation</i> part of this Certificate.
Regulation:	9	Building standards applicable to construction
Standard:	3.10	Precipitation
Comment:		The product will contribute to a wall satisfying clauses 3.10.1 ⁽¹⁾⁽²⁾ and 3.10.5 ⁽¹⁾⁽²⁾ of this Standard. See section 6.1 of this Certificate.
Standard:	3.15	Condensation
Comment:		The product can contribute to limiting the risk of condensation with reference to clauses 3.15.1 ⁽¹⁾⁽²⁾ and 3.15.5 ⁽¹⁾⁽²⁾ of this Standard. See section 7.1 of this Certificate.
Standard:	7.1(a)	Statement of sustainability
Comment:		The product can contribute to satisfying the relevant requirements of Regulation 9, Standards 1 to 6, and therefore will contribute to a construction meeting a bronze level of sustainability as defined in this Standard.
Regulation:	12	Building standards applicable to conversions
Comment:		Comments in relation to the product under Regulation 9, Standards 1 to 6, also apply to this Regulation, with reference to clause 0.12.1 ⁽¹⁾⁽²⁾ and Schedule 6 ⁽¹⁾⁽²⁾ .

(1) Technical Handbook (Domestic).

(2) Technical Handbook (Non-Domestic).



The Building Regulations (Northern Ireland) 2012 (as amended)

Regulation:	23(a)(i)	Fitness of materials and workmanship
Comment:	(iii)(b)(i)	The product is acceptable. See section 11 and the <i>Installation</i> part of this Certificate.
Regulation:	28(a)	Resistance to moisture and weather
Comment:		The product will contribute to a wall satisfying this Regulation. See section 6.1 of this Certificate.
Regulation:	29	Condensation
Comment:		The product can contribute to limiting the risk of condensation. See section 7.1 of this Certificate.

Construction (Design and Management) Regulations 2015

Construction (Design and Management) Regulations (Northern Ireland) 2016

Information in this Certificate may assist the client, designer (including Principal Designer) and contractor (including Principal Contractor) to address their obligations under these Regulations.

See section: 1 *Description* (1.1) of this Certificate.

Additional Information

NHBC Standards 2019

In the opinion of the BBA, Fireshield, if installed, used and maintained in accordance with this Certificate, can satisfy or contribute to satisfying the relevant requirements in relation to *NHBC Standards*, Chapters 6.1 *External masonry walls*, 6.2 *External timber frame walls*, 6.9 *Curtain walling and cladding* and 6.10 *Light steel framed walls and floors*.

CE marking

The Certificate holder has taken the responsibility of CE marking the product in accordance with harmonised European Standard BS EN 13859-2 : 2014. An asterisk (*) appearing in this Certificate indicates that data shown are given in the manufacturer's Declaration of Performance.

Technical Specification

1 Description

1.1 Fireshield is for use in wall applications and comprises a water-vapour-permeable film between one layer of non-woven spunbonded polypropylene, and one layer of glass fibre fleece which has been coated with a graphite compound. The product has the nominal characteristics given in Table 1.

Characteristic (unit)	Value
Thickness (mm)	1.2
Mass per unit area ($\text{g}\cdot\text{m}^{-2}$)	737
Roll length (m)	20
Roll width (m)	1.1
Tensile strength ($\text{N}\cdot 50\text{ mm}^{-1}$)	
longitudinal	300 ⁽¹⁾
transverse	275 ⁽¹⁾
Elongation* (%)	
longitudinal	2-3
transverse	2-3
Tear resistance (N)	
longitudinal	273.18
transverse	330.63
Watertightness	
unaged	W1
aged	W1
Equivalent air layer thickness* (S_d) (m)	0.08
Resistance to penetration of air ($\text{m}^3/\text{m}^2\cdot\text{h}\cdot 50\text{ Pa}^{-1}$)	1

1.2 Ancillary items for use with the product, but outside the scope of this Certificate, are

- Reflectafoil – an aluminium foil backed tape for sealing corner details
- Flexitite – a scrim reinforced elastical film tape.

2 Manufacture

2.1 The membrane is manufactured by lamination of a water-vapour-permeable film between one layer of non-woven spunbonded polypropylene, and one layer of glass fibre fleece which has been coated with a graphite compound to form a flexible, vapour-permeable membrane.

2.2 As part of the assessment and ongoing surveillance of product quality, the BBA has:

- agreed with the manufacturer the quality control procedures and product testing to be undertaken
- assessed and agreed the quality control operated over batches of incoming materials
- monitored the production process and verified that it is in accordance with the documented process
- evaluated the process for management of nonconformities
- checked that equipment has been properly tested and calibrated
- undertaken to carry out the above measures on a regular basis through a surveillance process, to verify that the specifications and quality control being operated by the manufacturer are being maintained.

2.3 The management system of the manufacturer has been assessed and registered as meeting the requirements of BS EN ISO 9001 : 2015 by DVL GL (Certificate 113901-2012-AQ-ITA-ACCREDIA).

3 Delivery and site handling

3.1 Rolls are delivered to site individually wrapped in polythene bearing the product name and the BBA logo incorporating the number of the Certificate.

3.2 The rolls should be stored on end on a smooth, clean, dry surface, under cover and protected from sunlight.

Assessment and Technical Investigations

The following is a summary of the assessment and technical investigations carried out on Fireshield.

Design Considerations

4 Use

4.1 Fireshield is satisfactory for use as a fire retardant, vapour permeable membrane in walls of timber-, masonry- and steel-frame construction, either factory or site applied.

4.2 In the absence of other guidance, suitable walls are defined as those designed and built in accordance with *NHBC Standards* 2019, Chapters 6.1, 6.2, 6.9 and 6.10.

4.3 The product satisfies the NHBC requirements given in *NHBC Standards* 2019.

4.4 The membrane can be damaged by high winds, careless handling or vandalism and should not be left exposed for longer than is absolutely necessary. Any damaged areas must be repaired or replaced before completion in accordance with section 15.

5 Practicability of installation

The product is designed to be installed by a competent builder experienced with this type of product.

6 Weathertightness



6.1 The product is classified as Class W1* in accordance with BS EN 13859-2 : 2014 and will resist liquid water penetration and wind-blown snow, and will protect the sheathing from external moisture.

6.2 The period prior to the installation of the outer covering should be kept to a minimum. The membrane should not be used as a temporary waterproof covering during this time

7 Risk of condensation



7.1 The product has a design resistance to water vapour transmission of less than $0.6 \text{ MN}\cdot\text{s}\cdot\text{g}^{-1}$ and is defined as a breather membrane in accordance with BS 5250 : 2011. It will therefore contribute towards minimising the risk of interstitial condensation in walls designed and constructed in accordance with BS 5250 : 2011, Annex G, Section G4

7.2 The risk of condensation occurring within the wall of a building will depend upon the properties and vapour resistance of other materials used in the construction, the internal and external conditions and the effectiveness of the internal vapour control layer.

8 Strength

The product will resist the normal loads associated with construction and installation of wall constructions.

9 Behaviour in relation to fire

9.1 Fireshield is classified B s1, d0⁽¹⁾ accordance with BS EN 13501-1 : 2007.

(1) The fire classification elements are defined as Class B:

- fire growth rate index tested to EN 13823 : 2002 – FIGRA $_{0.2\text{MJ}}$ — compliant
- fire growth rate index tested to EN 13823 : 2002 – FIGRA $_{0.4\text{MJ}}$ — compliant
- lateral flame spread tested to EN 13823 : 2002 – LFS < edge of specimen
- total heat release tested to EN 13823 : 2002 – THR_{600s} 0.6 MJ — compliant
- flame height tested to EN ISO 11925-2 : 2010 – $F_s \leq 15$ cm within 60 seconds with a flaming time of 30 seconds
- s1 smoke production — a smoke growth rate SMOGRA $30 \text{ m}^2\cdot\text{s}^2$ 1 — compliant
- total smoke production TSP_{600s} 32 m^2 — compliant
- droplets/particles tested to EN 13823 : 2002 — d0 no flaming droplets/particles.

9.2 Cavity barriers should be used to satisfy the requirements of the national Building Regulations.

10 Maintenance

As the product is confined within the wall space and has suitable durability, maintenance is not required. However, any damage occurring before enclosure must be repaired (see section 15).

11 Durability



The product will have a service life equal to that of the building in which it is installed.

12 Reuse and recyclability

The product contain polyolefins, which can be recycled.

Installation

13 General

Fireshield must be installed in accordance with this Certificate, the Certificate holder's instructions and the relevant recommendations of *NHBC Standards* 2019, Chapters 6.1, 6.2, 6.9 and 6.10.

14 Procedure

14.1 The product must be secured at regular intervals not exceeding 500 mm with austenitic stainless steel staples or nails to prevent damage by wind action.

14.2 Upper layers should overlap lower layers to shed water away from the sheathing. Vertical laps should be staggered wherever possible (see Figure 1).

Figure 1 Membrane installation

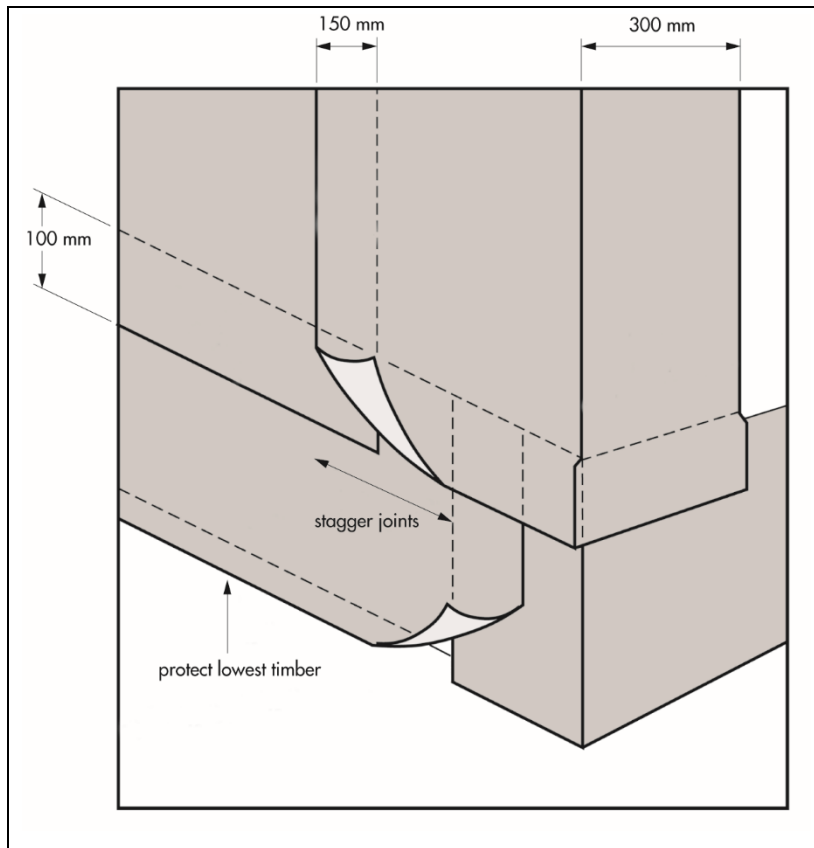

Figure 2 Corner detail

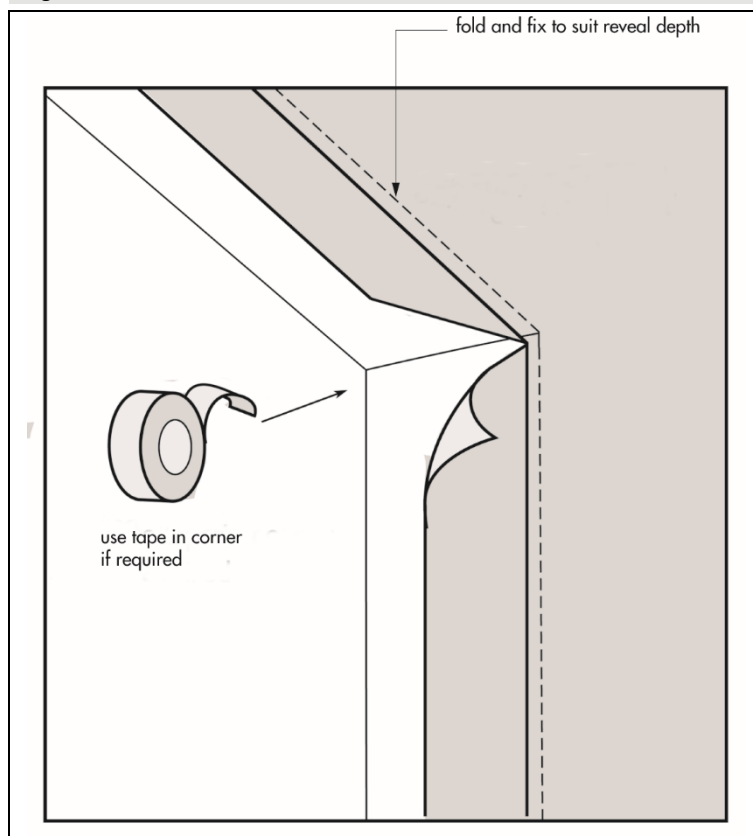
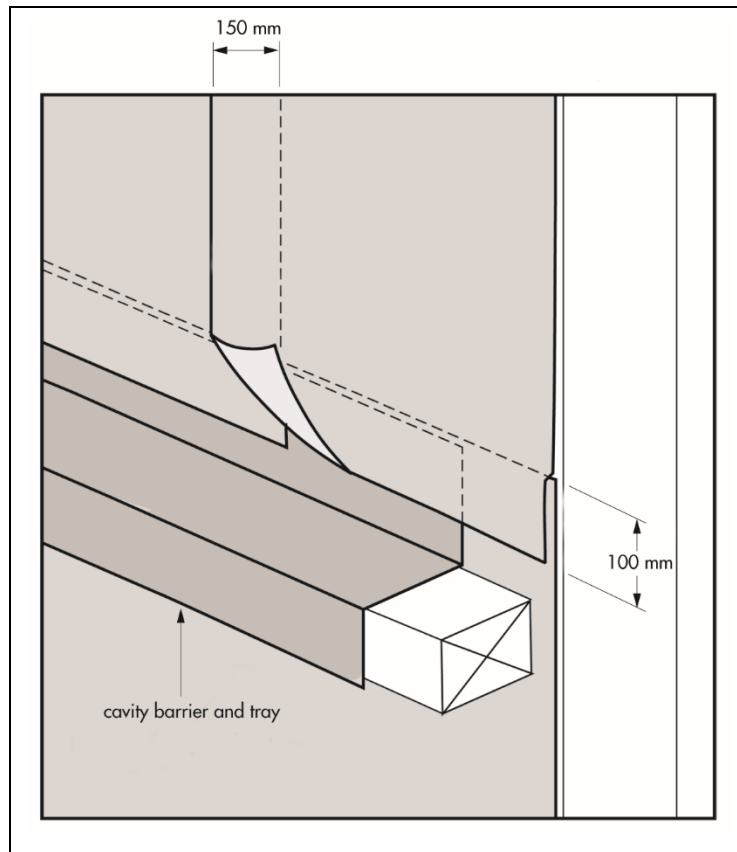

Figure 3 Cavity barrier and tray detail



14.3 Horizontal laps should be at least 100 mm and vertical laps at least 150 mm.

14.4 It is essential that the positions of studs are marked on the face of the membrane, preferably by tape, to enable fixing of wall ties or battens.

14.5 It is essential that the lowest timbers in the wall are protected by the membrane.

15 Repair

Damage to the membrane can be repaired prior to the installation of external walls or claddings by laying another sheet over the damaged areas and sealing it correctly, ensuring that water is shed away from the sheathing.

Technical Investigations

16 Tests

An assessment was made of data to BS EN 13859-2 : 2014 in relation to:

- reaction to fire
- dimensions
- mass per unit area
- tensile strength and elongation
- resistance to tear
- dimensional stability
- water resistance
- water penetration
- hydrostatic head
- resistance to artificial ageing
- low temperature flexibility
- water vapour transmission.

17 Investigations

The manufacturing process was evaluated, including the methods adopted for quality control, and details were obtained of the quality and composition of the materials used.

Bibliography

BS 5250 : 2011 + A1 : 2016 *Code of practice for control of condensation in buildings*

BS EN 13501-1 : 2007 + A1 : 2009 *Fire classification of construction products and building elements — Classification using test data from reaction to fire tests*

EN 13823 : 2002 *Reaction to fire tests for building products — Building products excluding floorings exposed to the thermal attack by a single burning item*

BS EN 13859-2 : 2014 *Flexible sheet for waterproofing — Definitions and characteristics of underlays — Underlays for walls*

BS EN ISO 9001 : 2015 *Quality management systems — Requirements*

EN ISO 11925-2 : 2010 *Reaction to fire tests — Ignitability of products subjected to direct impingement of flame — Single-flame source test*

18 Conditions

18.1 This Certificate:

- relates only to the product/system that is named and described on the front page
- is issued only to the company, firm, organisation or person named on the front page – no other company, firm, organisation or person may hold or claim that this Certificate has been issued to them
- is valid only within the UK
- has to be read, considered and used as a whole document – it may be misleading and will be incomplete to be selective
- is copyright of the BBA
- is subject to English Law.

18.2 Publications, documents, specifications, legislation, regulations, standards and the like referenced in this Certificate are those that were current and/or deemed relevant by the BBA at the date of issue or reissue of this Certificate.

18.3 This Certificate will remain valid for an unlimited period provided that the product/system and its manufacture and/or fabrication, including all related and relevant parts and processes thereof:

- are maintained at or above the levels which have been assessed and found to be satisfactory by the BBA
- continue to be checked as and when deemed appropriate by the BBA under arrangements that it will determine
- are reviewed by the BBA as and when it considers appropriate.

18.4 The BBA has used due skill, care and diligence in preparing this Certificate, but no warranty is provided.

18.5 In issuing this Certificate the BBA is not responsible and is excluded from any liability to any company, firm, organisation or person, for any matters arising directly or indirectly from:

- the presence or absence of any patent, intellectual property or similar rights subsisting in the product/system or any other product/system
- the right of the Certificate holder to manufacture, supply, install, maintain or market the product/system
- actual installations of the product/system, including their nature, design, methods, performance, workmanship and maintenance
- any works and constructions in which the product/system is installed, including their nature, design, methods, performance, workmanship and maintenance
- any loss or damage, including personal injury, howsoever caused by the product/system, including its manufacture, supply, installation, use, maintenance and removal
- any claims by the manufacturer relating to CE marking.

18.6 Any information relating to the manufacture, supply, installation, use, maintenance and removal of this product/system which is contained or referred to in this Certificate is the minimum required to be met when the product/system is manufactured, supplied, installed, used, maintained and removed. It does not purport in any way to restate the requirements of the Health and Safety at Work etc. Act 1974, or of any other statutory, common law or other duty which may exist at the date of issue or reissue of this Certificate; nor is conformity with such information to be taken as satisfying the requirements of the 1974 Act or of any statutory, common law or other duty of care.